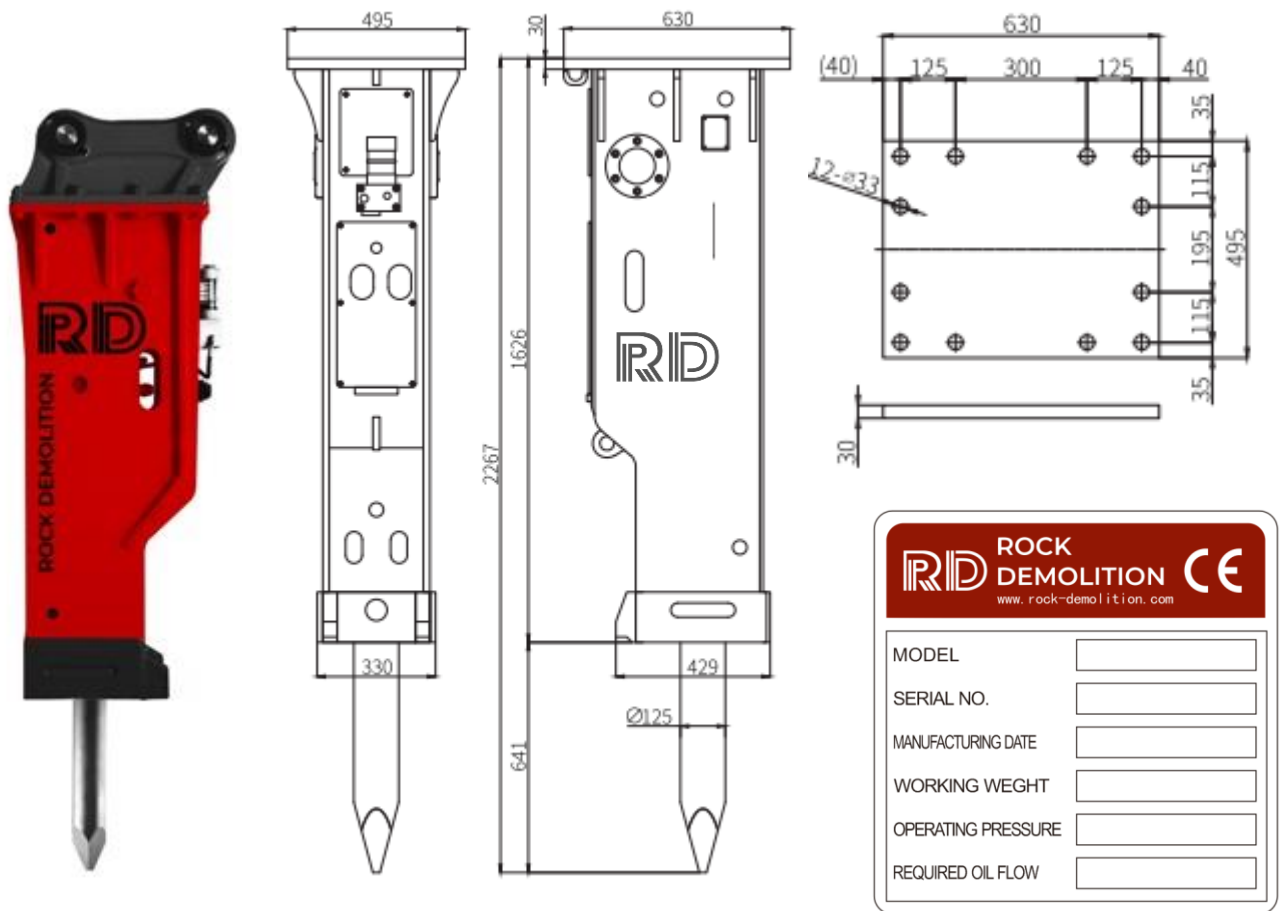

**RD-125**

MODEL	<input type="text"/>
SERIAL NO.	<input type="text"/>
MANUFACTURING DATE	<input type="text"/>
WORKING WEGHT	<input type="text"/>
OPERATING PRESSURE	<input type="text"/>
REQUIRED OIL FLOW	<input type="text"/>

## Spécifications technique

FRANCAIS	ENGLISH		<b>RD-125</b>
POIDS EN ORDRE DE MARCHE	WORKING WEIGHT	Kg	<b>1357</b>
LONGUEUR SYSTÈME DE FRAPPE	CYLINDER LENGHT	mm	<b>1543</b>
LONGUEUR TOTALE	TOTAL LENGHT	mm	<b>2609</b>
DEBIT D'HUILE	REQUIRED OIL FLOW	L/min	<b>90-120</b>
PRESSION DE TRAVAIL	WORKING PRESSURE	Bar	<b>150-170</b>
COUPS/MINUTE	IMPACTE RATE	bpm	<b>350-650</b>
DIAMETRE OUTIL	CHISEL LENGHT	mm	<b>125</b>
CONNECTION FLEXIBLES	HOSE DIAMETER	inch	<b>1</b>
PRESSION PISTON ACCUMULATEUR	BACK HEAD PRESSUR	kg/cm2	<b>14/17</b>
POIDS DU PORTEUR	APPLICABLE EXCAVATOR	tonne	<b>18-25</b>
FORCE D'IMPACT	IMPACT POWER	Joule	<b>2550</b>